

Technical data:

Operating voltage	10...30 V DC
Rated current	4 A
Insulation resistance	> 1000 MΩ
Ambient temperature range	-40...70 °C

Protection:

Degree of protection	IP67
----------------------	------

M12 straight male connector :

Locking nut/screw material	Zamak, nickel-plated
Overmoulding material	TPU, self-extinguishing
Contact diameter	Ø1 mm
Contact material	CuZn, pre-plated with nickel and gold-plated
Contact resistance	< 5 mΩ

M12 angled female connector (LEDs) :

Locking nut/screw material	Zamak, nickel-plated
Overmoulding material	TPU, self-extinguishing
Contact diameter	Ø1 mm
Contact material	CuZn, pre-plated with nickel and gold-plated
Contact resistance	< 5 mΩ
LED(s) colour	LEDs (YE / RD / GN)
Type of LED compatibility	PNP
Power consumption per LED	< 5 mA

State indication :

Signal (2)	Red LED
Signal (4)	Yellow LED
Voltage present	Green LED

Cable characteristics :

Sheath material	Irradiated PUR, halogen free
Cable composition	1 G 0,5mm ² + 4 x 0,34 mm ²
Conductor class	5
Sheath diameter	5,2 mm
Flame resistance according to	IEC 60332-1 (VDE 0472-804/B)
Oil resistance according to	EN 50363 & IEC 60811-2-1

Cable length:

L standard lengths	1 m / 2 m / 5 m / 10 m
L length, on request	Please enquire
Reference: replace «...» by length required:	1/2/5/10

Accessories (included):

2 label holders

L12/5MLP3...2V

Industrial automation



Dimensions :

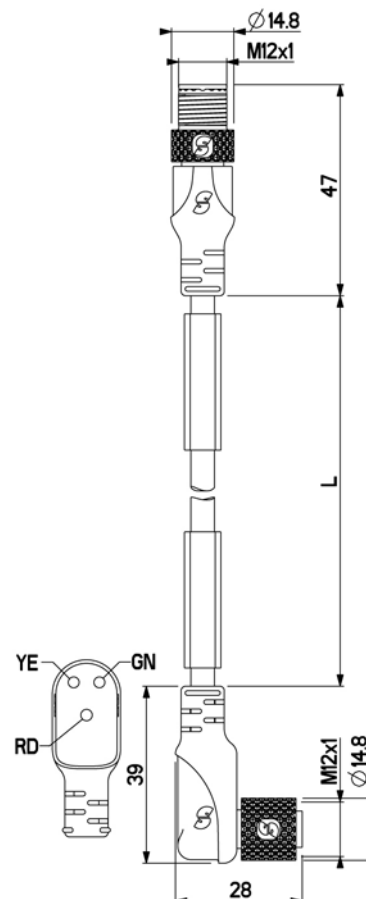

Wiring diagram:

