

Technical data :

Rated operating distance (Sn)	5 mm
Output type	PNP/NPN
Operating voltage	12...28 V DC
Operating current	150 mA
No-load consumption	< 70 mA
Voltage drop	< 3 V
Residual current	< 70 µA
Ambient temperature range	-20...60 °C
Repeatability	0,15 mm
Switching frequency	> 20 kHz
Reaction time	< 0,25 µs
Power-on delay	< 100 ms

Optical characteristics :

Light type	Permanent infrared
Minimum target size	Ø 0,3 mm
Ambient light immunity	5 klx

Protection :

Reverse polarity protection	
Short-circuit protection	
Overload protection	
IEC 61000-4-2 (ESD)	4 kV contact / 8kV air
IEC 61000-4-4 (Burst)	2kV / 5kHz
IEC 61000-4-6 (RF conducted)	3V 150kHz...80MHz
Protection degree	IP67

Materials :

Housing	Anodized aluminium
Sensing face	PMMA

Status indication :

Detection	Red LED
Non-detection	Green LED

Connection :

Connector	Amphenol C091
Cable	PUR (4x0,14mm ²)
Cable length	1 m

Accessories (included) :

Amplifier (G12P3HAQ40304)

Accessories (not included) :

Female connector (L16/7L01)

EXXR51U310541B
 Positioning series
 U5



Dimensions :

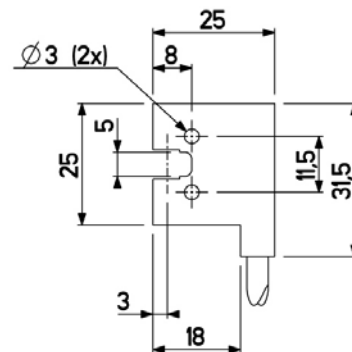

Details view (amplifier) :

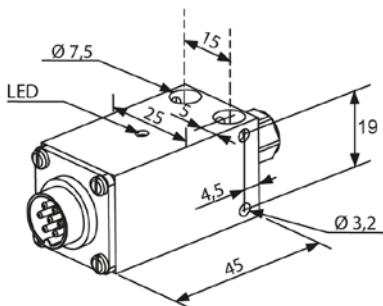

Connection diagram :

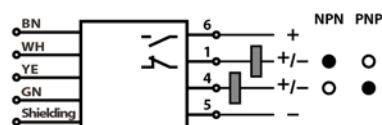

Pin assignment :

