

Technical data :

Function	NC
Operating voltage	10...55 V DC
Operating current	100 mA
Voltage drop	< 5 V
Residual current	< 600 μ A
Ambient temperature range	-25...70 °C
Hysteresis	3...15 %
Repeatability	< 5 %
Switching frequency	20 Hz
Slide's total stroke	1,8 mm +/- 0,3 mm
Force to be applied to the slide for detecting	< 2,5 N
Slide's biasing force	> 0,9 N

Protection :

Non-polarised	
Short-circuit protection	
Overload protection	
IEC 61000-4-2 (ESD)	4 kV contact / 8kV air
IEC 61000-4-4 (Burst)	2kV / 5kHz
IEC 61000-4-6 (RF conducted)	3V 150kHz...80MHz
Protection degree	IP67

Materials :

Housing	Brass, nickel-plated
Slide	Stainless steel

Status indication :

Output	Yellow LED
--------	------------

Connection :

Connector	M12
Cable	Halogen free PUR
Cable length	0,8 m

Accessories (included) :

Transmitter (TRSPY)

A1292D8L12SP11

Poka-Yoke



Dimensions :

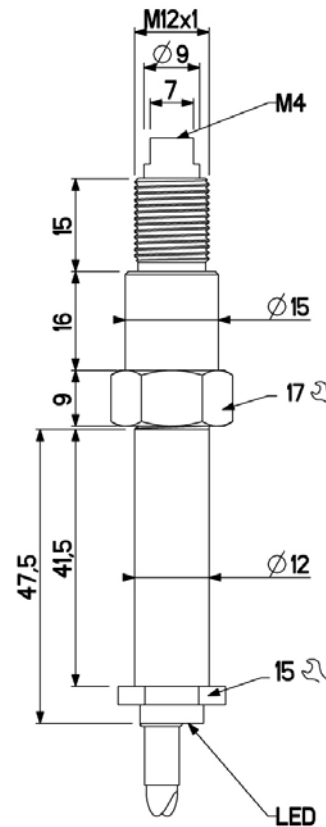

Connection diagram :

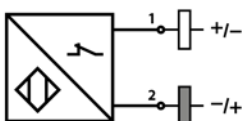

Pin assignment :

